

ComfortEDGE SLIDING WINDOW

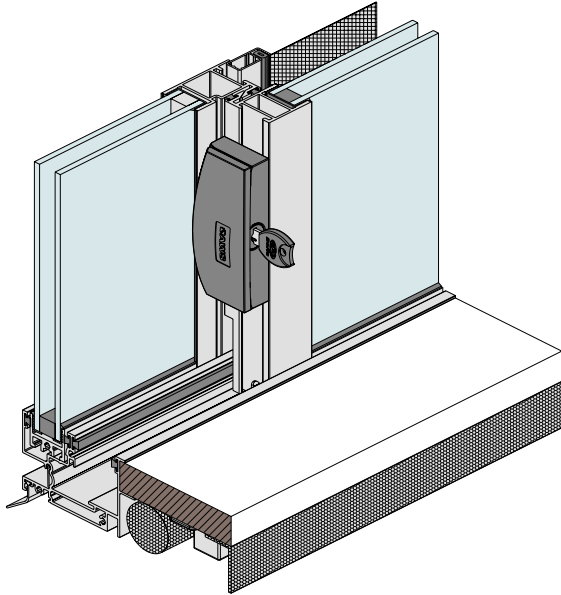

KEY FEATURES

- Series 753 ComfortEDGE™ sliding window is an energy efficient window system designed to have minimised sightline from the aluminium frame and sash.
- The sash is concealed below the reveal and maintains the same sightlines as the fixed lights. This greatly enhances thermal performance by reducing the exposed internal boundary condition and also achieves a clean minimalist architectural look on both the inside and outside.
- The window has a unique patent thermal seal fitted to the essential top single reveal that greatly reduces thermal transmission through the window. The window can also be fitted with twin reveals for conventional window installation.
- Optional meeting stiles, mullions and transoms strengths cover a large variety of design wind load areas.
- Will accept 18 to 20mm IGU's allowing the inclusion of high performance glazing systems.
- Several sash sizes have been successfully tested by an independent NATA accredited testing facility for Safe4kids in accordance with BCA restricted opening.

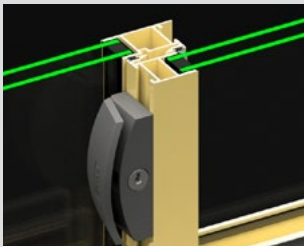

Centre mullion key locks or alternate jamb locks are available to ensure security and peace of mind.

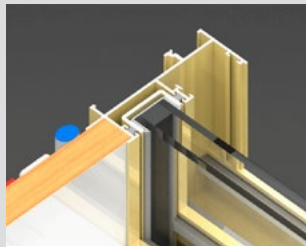

The sash is concealed below the reveal and maintains the same sightlines as the fixed lights for greatly enhanced thermal performance.

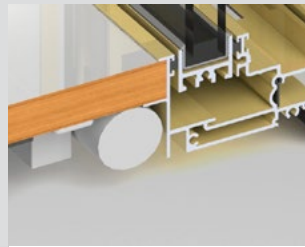

The window's unique, patent thermal seal fitted to the essential top single reveal greatly reduces thermal transmission through the window.



Concealed sashes give a clean minimalist architectural look on both the inside and outside.

GENERAL

Max Panel Height*
1500mm

Max Panel Width*
1000mm

Max Glass Thickness
20mm

Frame Depth
75mm

ENERGY

UW Range
2.6 – 3.6

SHGC Range
0.23 - 0.61

WEATHER

Maximum Water
300Pa

ACOUSTICS

This product has not been acoustics tested. AWS anticipates this product's acoustic performance will be in-line with Series 504

